



**Commercial Systems**  
Australia Pty. Ltd.



**DIMENSIONS**

Capacity: to suit 120 litre wheelie bins  
Length: 638mm  
Height: 1213mm  
Width: 638mm

**MATERIALS**

Frame: Mild Steel  
Battens: Blackbutt timbers; or  
EnviroSlat composite recycled plastic  
Lid: 304 grade stainless steel

**FINISHES**

Frame: Powdercoated any standard Dulux Powdercoat colour  
Timbers: Quantum Oil finishes  
Lid: Satin polished stainless steel

**FIXINGS**

1. Bolt Fixed  
Drill through base and bolt into concrete pad  
Bolts: M12 zinc plated Dynabolts

**RECYCLING**

Coordinates well with the LR 6158 MSTR recycling bin enclosure.

**OTHER OPTIONS**

Capacity: 80litre and 240 litre  
Timbers: Alternative timbers available including recycled timbers  
Battens can run vertically  
Lid: Mild Steel  
Over 12 lids to choose from  
Design: Custom decals, labels and signage  
Call and talk to one of our Product Design engineers to discuss other custom requirements

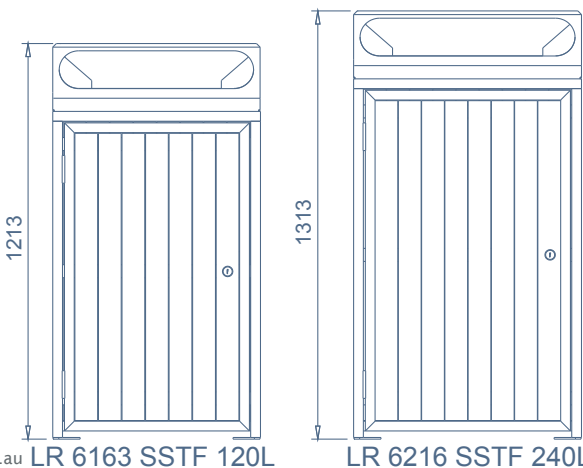
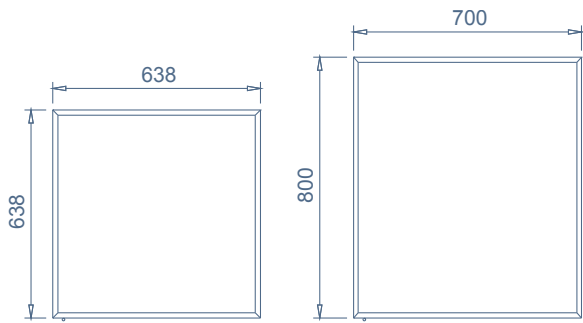

LR 6163 SSTF 120L

LR 6216 SSTF 240L

**Commercial Systems**  
Australia Pty. Ltd.

49-51 Vinter Avenue  
Croydon 3136  
Victoria, Australia

Phone: (03) 9725 9344  
Fax: (03) 9725 9744  
web: www.commercialsystems.com.au

# SSTF Timber

**LR 6163 SSTF 120L**  
**LR 6216 SSTF 240L**

Timber Litter Bin Enclosure with Tapered Front Entry Lid