



Commercial Systems
Australia Pty. Ltd.



DIMENSIONS

Capacity: to suit 120 litre wheelie bins
Length: 638mm
Height: 1063mm
Width: 638mm

MATERIALS

Frame: Mild Steel
Battens: Blackbutt timbers; or
EnviroSlat composite recycled plastic
Lid: 304 grade Stainless Steel

FINISHES

Frame: Powdercoated any standard Dulux Powdercoat colour
Timbers: Quantum Oil finishes
Lid: Satin polished stainless steel

FIXINGS

1. Bolt Fixed
Drill through base and bolt into concrete pad
Bolts: M12 zinc plated Dynabolts

RECYCLING

Coordinates well with the LR 6158 MSTR recycling bin enclosure.

OTHER OPTIONS

Capacity: 80litre and 240 litre
Timbers: Alternative timbers available including recycled timbers
Battens can run vertically
Lid: Over 12 lids to choose from
Design: Custom decals, labels and signage
Call and talk to one of our Product Design engineers to discuss other custom requirements

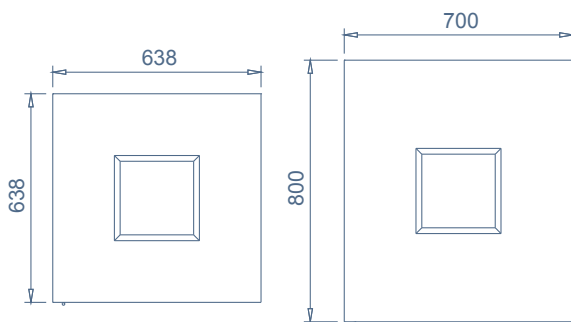

LR 6163 SSF 120L

LR 6216 SSF 240L

Commercial Systems
Australia Pty. Ltd.

49-51 Vinter Avenue
Croydon 3136
Victoria, Australia

Phone: (03) 9725 9344
Fax: (03) 9725 9744
web: www.commercialsystems.com.au

SSF Timber

LR 6163 SSF 120L
LR 6216 SSF 240L

Timber Litter Bin Enclosure with Stainless Steel Flat Lid