

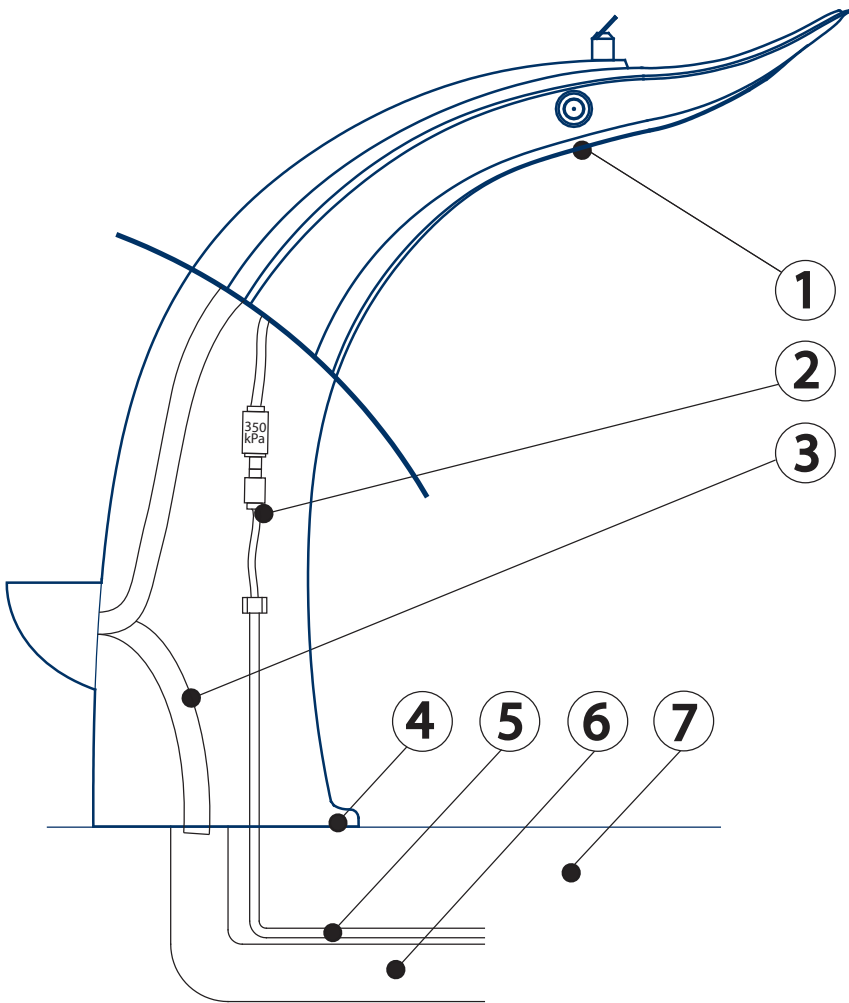

**Commercial Systems  
Australia Pty. Ltd.**

49-51 Vinter Avenue  
Croydon 3136  
Victoria, Australia

Phone: (03) 9725 9344  
Fax: (03) 9725 9744  
web: www.commercialsystems.com.au



#### INSTRUCTIONS <sup>1</sup>

##### FIXING:

Bolt Fixed

Drill through base and bolt into concrete pad

Bolts: 4 x M10 x 75mm, zinc plated Dynabolts  
(Base plate dimensions shown below)

##### PLUMBING:

Preparation:

Make sure the installation site for the footing of the fountain is flat and level (7). Also check that the concrete is at least 100mm thick at this location.

Plumb inlet and outlet to the position where the fountain is to be installed. These pipes must protrude from the ground within 100mm of each other.

Water supply to the fountain should be a 1/2" Copper pipe (5). Recommend minimum 50mm diameter pipe for waste to storm water (6). This should protrude just above ground level.

Installation:

Remove the access doors from the fountain and sit it over the inlet and outlet pipes. Mark the positions of the four bolt down holes, remove the fountain and drill the dynabolt holes (4).

**WARNING:** Make sure these holes are clear of the plumbing pipes.

Move the fountain back into position and insert the dynabolts through the base and knock them into the ground. Through the access door, move the 40mm OD flexi drain pipe<sup>2</sup> (3, supplied) and sit it in the waste pipe (6). Connect the 1/2" inlet (5) to the fountain with a male 1/2" BSP copper connection into the bottom of the supplied 350kPa pressure regulator (2).

Test the plumbing connections and fountain operation before finally tightening the dynabolts and reattaching the access doors.

##### ADJUSTMENT

Turn the small flat head screw on the inlet connection of the button inside the fountain (1) to adjust the valve and regulate flow.

##### OVERALL FOUNTAIN DIMENSIONS

Length: 890mm

Height: 960mm

Width: 320mm

<sup>1</sup> Installation and connection of plumbing components to be performed by a licensed contractor.

<sup>2</sup> If optional dog bowl is installed, the drain pipe will run from the outlet of the bowl.

##### FOOTING DETAIL

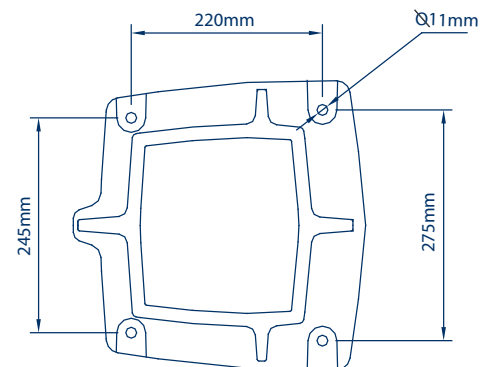

# Banyan Drinking Fountain

## Installation Instructions